

DESCRIPTION

PD (Powered Device) Integrated Module (Isolation Type)

FEATURES

- Fully IEEE 802.3af/at compliant
- 24 watt output load
- IEEE Power class programmable (Green)
- 1500 Volt DC isolation (Input to Output)
- 5V, 12V ,24V DC output voltage models
- Compact package minimum PCB footprint
- Minimal external components required
- Overload and short circuit protection
- Wide input voltage (36V to 57V DC)
- Adjustable output voltage
- Support PoE applications in both of Fast / Gigabit Ethernet environments.
- Low output ripple and noise
- Low cost



APPLICATION AREAS

- Security and alarm systems
- Voice over IP phones
- Access control systems
- IP Cameras
- Displays, Net Monitors
- Public address systems
- Wireless access points
- Environmental control
- Telemetry
- Remote environmental monitoring

1 Product Overview

1.1 IT5700 Product Selector

Part Number	Nominal Output Voltage	Output Power	
		70°C	85°C
IT5705LPB	5.0V	24 Watts	20 Watts
IT5712LPB	12.0V	24 Watts	24 Watts
IT5724LPB	24.0V	24 Watts	20 Watts

Table 1: Ordering Information

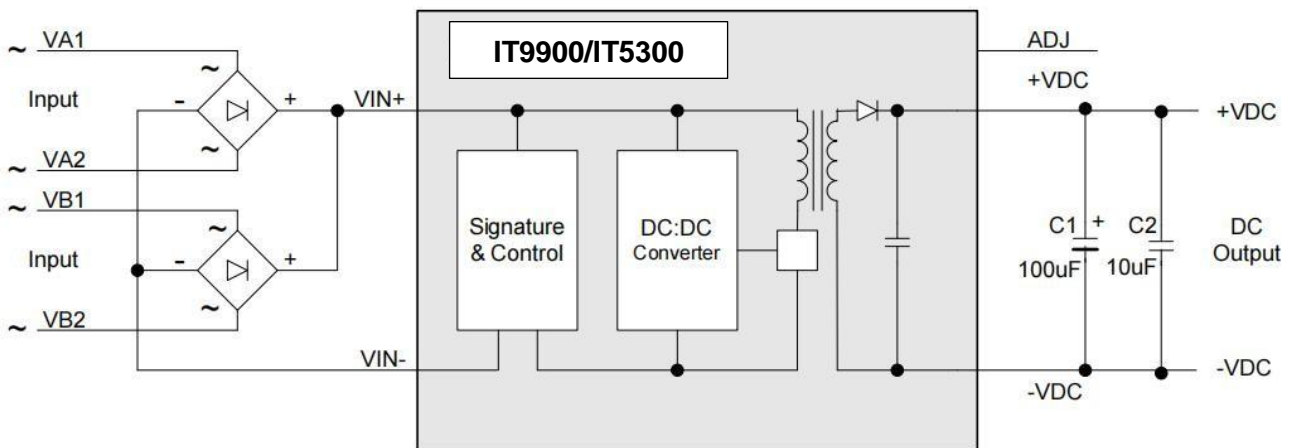

Figure 1: Block Diagram

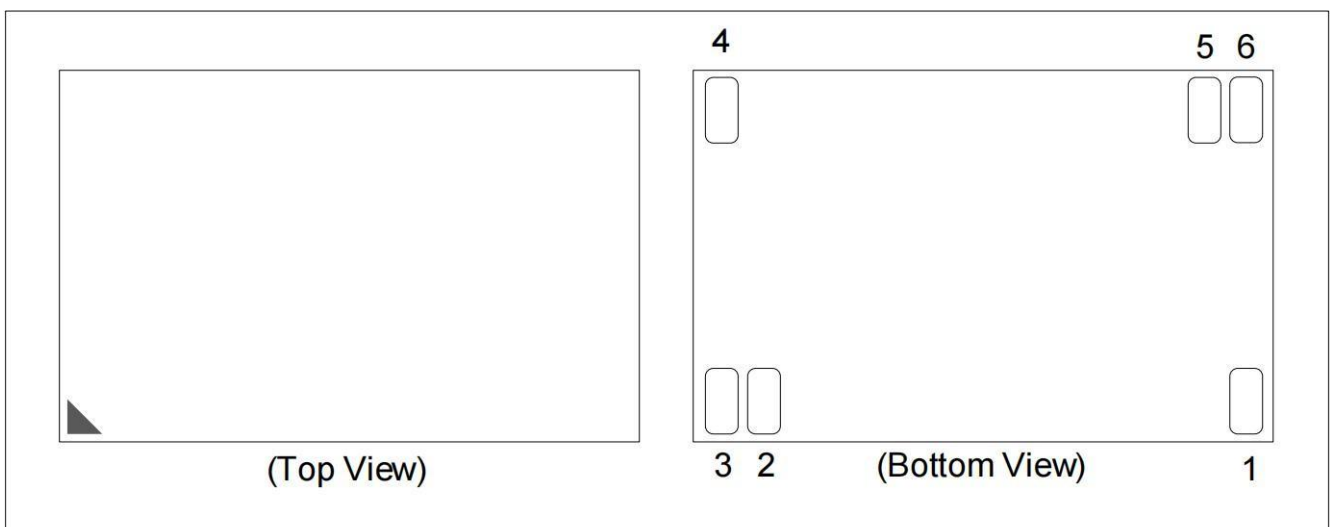

Figure 2: IT5700 Package Format

1.2 Pin Description

Pin #	Name	Description
1	+VDC	Positive DC Output. This pin provides the positive regulated output from the IT5700.
2	-VDC	DC Return. This pin provides the negative regulated output from the IT5700.
3	ADJ	Output Adjust. The output voltage can be adjusted from its nominal value, by connecting an external resistor from this pin to either the +VDC pin or the -VDC pin.
4	VIN+	Direct Input +. This pin connects to the positive (+) output of the input bridge rectifiers.
5	TYP2-DET	Type 2 Detect Output. This pin indicates if an IEEE802.3at PSE is supplying power to the IT5700.
6	VIN-	Direct Input -. This pin connects to the negative (-) output of the input bridge rectifiers.

Table 2: Pin Description

2 Functional Description

2.1 Typical Connections

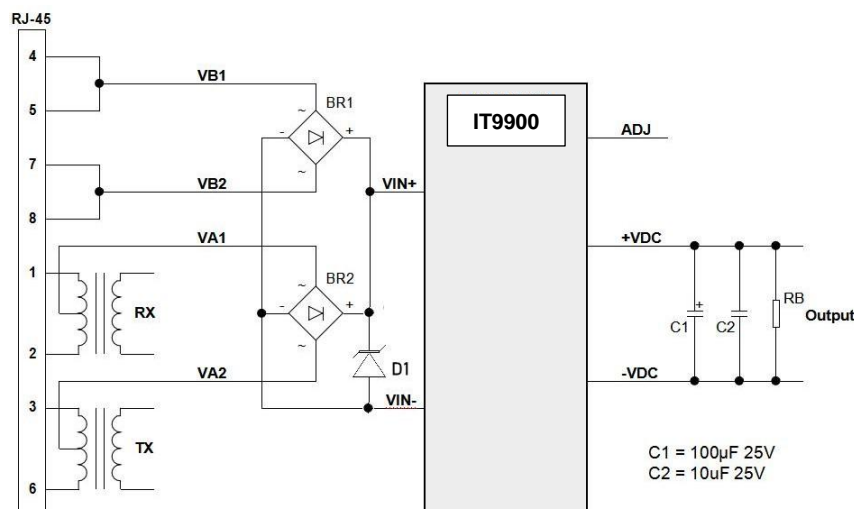

Figure 3: Typical Connection Diagram

BR1, BR2=MB6S; D1=SMAJ58A; RB= \geq I Load min

2.2 Output Voltage Adjustment

The IT5700 series has an ADJ pin, which allows the output voltage to be increased or decreased. Figure 4 shows how the ADJ pin is connected.

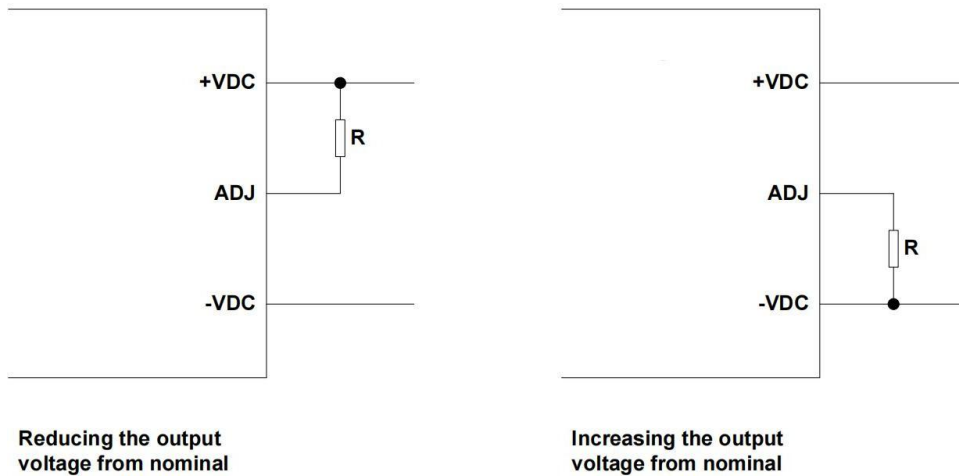

Figure 4: Output Adjustment

Reducing the output voltage, connect R between ADJ and +VDC			
Value of R	IT5705 output	IT5712 Output	IT5724 Output
Open Circuit	5.00V	12.07V	23.93V
0 Ohms	4.52V	10.0V	19.85V
100K	4.76V	11.15V	21.85V
470k	4.92V	11.76V	23.23V
Increasing the output voltage, connect R between ADJ and -VDC			
Value of R	IT5705 output	IT5712 output	IT5724 Output
Open Circuit	5.00V	12.07V	23.93V
0 Ohms	5.66V	12.75V	24.6V
100K	5.27V	12.34V	24.2V
470k	5.08V	12.16V	24.01V

Table 3: Output Adjustment Resistor (R) Value

3 Electrical Characteristics

3.1 Absolute Maximum Ratings

	Parameter	Symbol	Min	Max	Units
1	DC Supply Voltage	V_{CC}	-0.3	60	V
2	DC Supply Voltage Surge for 1ms	V_{SURGE}	-0.6	80	V
3	Storage Temperature	T_S	-40	+100	°C

3.2 Recommended Operating Conditions

	Parameter	Min	Typ	Max	Units
1	Input Supply Voltage	36	48	57	V
2	Under Voltage Lockout	30		36	V
3	Input Current		600	620	mA
4	Operating Temperature	-40	25	85	°C
5	IEEE 802.3af/at	Class 4			

3.3 DC Electrical Characteristics

	DC Characteristic	Variant	Sym	Min	Typ ¹	Max	Units
1	Nominal Output Voltage	IT5724LPB	+VDC	23.5	24	24.5	V
		IT5712LPB		11.6	12	12.4	
		IT5705LPB		4.75	5	5.25	
2	Minimum Load ²	IT5724LPB	I_{LOAD}	10			mA
		IT5712LPB		10			
		IT5705LPB		20			

	DC Characteristic	Variant	Sym	Min	Typ ¹	Max	Units
3	Output Current (VIN = 52V)	IT5724LPB	I _{out}			1	A
		IT5712LPB				2	
		IT5705LPB				4.8	
4	Line Regulation	IT5724LPB	V _{LINE}			0.15	%
		IT5712LPB				0.05	
		IT5705LPB				0.05	
5	Load Regulation – Min to Max (VIN = 52V)	IT5724LPB	V _{LOAD}			0.15	%
		IT5712LPB				0.1	
		IT5705LPB				0.1	
6	Output Ripple and Noises _{5@ Max load}	IT5724LPB	V _{RN}			TBD	mV _{p-p}
		IT5712LPB				200	
		IT5705LPB				TBD	
7	Peak Efficiency	IT5724LPB	EFF			91	%
		IT5712LPB					
		IT5705LPB					
8	Short-Circuit Duration ³		T _{SC}			∞	sec
9	Isolation Voltage (I/O) - Impulse Test		V _{ISO}			1500	V _{PK}

Note 1: Typical figures are at 25°C with a nominal 52V supply and are for design aid only. Not Guaranteed

Note 2: The module can emit an audible noise, if operated at less than the stated minimum I_{LOAD} and cause the PSE to fail its MPS.

Note 3: >200mohm short due to thermal limitation.

4 Package

IT5700LPB

